

# Low Noise Dual Supply Inverting Charge Pump

## FEATURES

- **V<sub>IN</sub> Range: 4.5V to 32V**
- **Inverting Charge Pump Generates -V<sub>IN</sub>**
- **Charge Pump Output Current Up to 100mA**
- **Low Noise Negative LDO Post Regulator**
- **(I<sub>LDO-</sub> = 50mA Max)**
- **Low Noise Independent Positive LDO Regulator**
- **(I<sub>LDO+</sub> = 50mA Max)**
- **100µA Quiescent Current in Burst Mode® Operation with Both LDO Regulators On**
- **50kHz to 500kHz Programmable Oscillator Frequency**
- **Stable with Ceramic Capacitors**
- **Short-Circuit/Thermal Protection**
- **Low Profile 3mm × 4mm 14-Pin DFN and Thermally Enhanced 16-Pin MSOP Packages**
- **AEC-Q100 Qualified for Automotive Applications**

## APPLICATIONS

- Low Noise Bipolar/Inverting Supplies
- Industrial/Instrumentation Low Noise Bias Generators
- Portable Medical Equipment
- Portable Instruments

## DESCRIPTION

The **LTC3260** is a low noise dual polarity output power supply that includes an inverting charge pump with both positive and negative LDO regulators. The charge pump operates over a wide 4.5V to 32V input range and can deliver up to 100mA of output current. Each LDO regulator can provide up to 50mA of output current. The negative LDO post regulator is powered from the charge pump output. The LDO output voltages can be adjusted using external resistor dividers.

The charge pump employs either low quiescent current Burst Mode operation or low noise constant frequency mode. In Burst Mode operation the charge pump V<sub>OUT</sub> regulates to -0.94 • V<sub>IN</sub>, and the LTC3260 draws only 100µA of quiescent current with both LDO regulators on. In constant frequency mode the charge pump produces an output equal to -V<sub>IN</sub> and operates at a fixed 500kHz or to a programmed value between 50kHz to 500kHz using an external resistor. The LTC3260 is available in low profile (0.75mm) 3mm x 4mm 14-pin DFN and thermally enhanced 16-pin MSOP packages.

All registered trademarks and trademarks are the property of their respective owners.

## TYPICAL APPLICATION

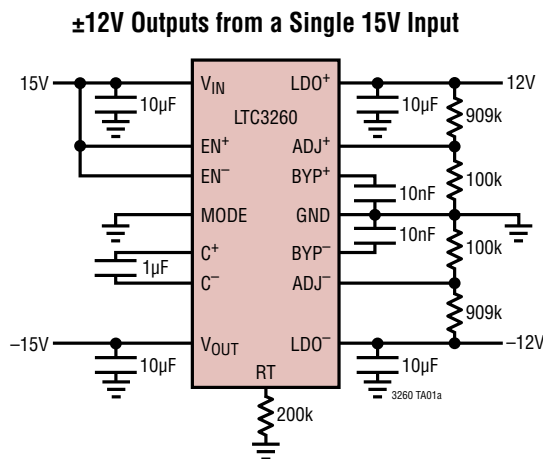

**LDO Rejection of V<sub>OUT</sub> Ripple**

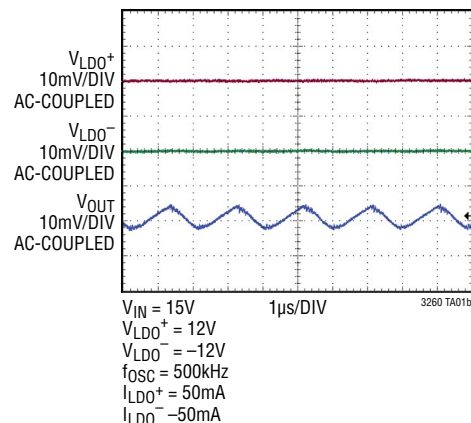

# LTC3260

## ABSOLUTE MAXIMUM RATINGS (Notes 1, 3)

$V_{IN}$ , $EN^+$ , $EN^-$ , $MODE$ .....	-0.3V to 36V	$V_{OUT}$ , $LDO^+$ , $LDO^-$ Short-Circuit Duration .....	Indefinite
$LDO^+$ .....	-16V to 36V	Operating Junction Temperature Range	
$V_{OUT}$ , $LDO^-$ .....	-36V to 0.3V	(Note 2).....	-55°C to 150°C
$RT$ , $ADJ^+$ .....	-0.3V to 6V	Storage Temperature Range .....	-65°C to 150°C
$BYP^+$ .....	-0.3V to 2.5V	Lead Temperature (Soldering, 10 sec)	
$ADJ^-$ .....	-6V to 0.3V	MSE Only .....	300°C
$BYP^-$ .....	-2.5V to 0.3V		

## PIN CONFIGURATION

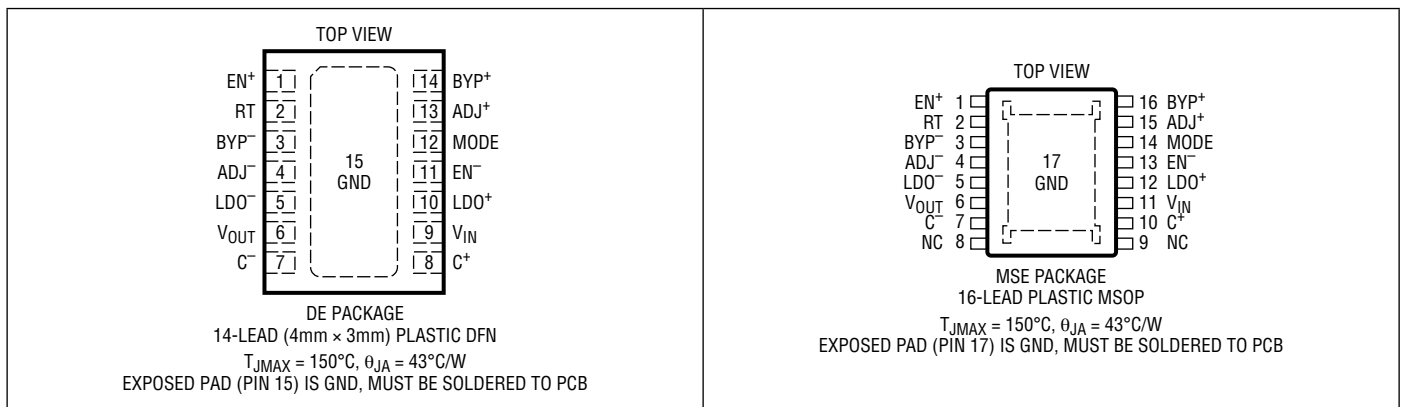

## ORDER INFORMATION

LEAD FREE FINISH	TAPE AND REEL	PART MARKING*	PACKAGE DESCRIPTION	TEMPERATURE RANGE
LTC3260EDE#PBF	LTC3260EDE#TRPBF	3260	14-Lead (4mm × 3mm) Plastic DFN	-40°C to 125°C
LTC3260IDE#PBF	LTC3260IDE#TRPBF	3260	14-Lead (4mm × 3mm) Plastic DFN	-40°C to 125°C
LTC3260EMSE#PBF	LTC3260EMSE#TRPBF	3260	16-Lead Plastic MSOP	-40°C to 125°C
LTC3260IMSE#PBF	LTC3260IMSE#TRPBF	3260	16-Lead Plastic MSOP	-40°C to 125°C
LTC3260HMSE#PBF	LTC3260HMSE#TRPBF	3260	16-Lead Plastic MSOP	-40°C to 150°C
LTC3260MPMSE#PBF	LTC3260MPMSE#TRPBF	3260	16-Lead Plastic MSOP	-55°C to 150°C

### AUTOMOTIVE PRODUCTS\*\*

LTC3260HMSE#WPBF	LTC3260HMSE#WTRPBF	3260	16-Lead Plastic MSOP	-40°C to 150°C
------------------	--------------------	------	----------------------	----------------

Contact the factory for parts specified with wider operating temperature ranges. \*The temperature grade is identified by a label on the shipping container.

**Tape and reel specifications.** Some packages are available in 500 unit reels through designated sales channels with #TRMPBF suffix.

\*\*Versions of this part are available with controlled manufacturing to support the quality and reliability requirements of automotive applications. These models are designated with a #W suffix. Only the automotive grade products shown are available for use in automotive applications. Contact your local Analog Devices account representative for specific product ordering information and to obtain the specific Automotive Reliability reports for these models.

## ELECTRICAL CHARACTERISTICS

The ● denotes the specifications which apply over the full operating junction temperature range, otherwise specifications are at  $T_A = 25^\circ\text{C}$  (Note 2).  $V_{IN} = EN^+ = EN^- = 12\text{V}$ ,  $MODE = 0\text{V}$ ,  $RT = 200\text{k}\Omega$ .

SYMBOL	PARAMETER	CONDITIONS	MIN	TYP	MAX	UNITS
<b>Charge Pump</b>						
$V_{IN}$	Input Voltage Range		● 4.5		32	V
$V_{UVLO}$	$V_{IN}$ Undervoltage Lockout Threshold	$V_{IN}$ Rising $V_{IN}$ Falling	● 3.4	3.8 3.6	4	V V
$I_{VIN}$	$V_{IN}$ Quiescent Current	Shutdown, $EN^+ = EN^- = 0\text{V}$ $EN^- = 0\text{V}$ , $I_{LDO^+} = 0\text{mA}$ $MODE = V_{IN}$ , $EN^+ = 0\text{V}$ , $I_{VOUT} = I_{LDO^-} = 0\text{mA}$ $MODE = V_{IN}$ , $I_{VOUT} = I_{LDO^+} = I_{LDO^-} = 0\text{mA}$ $MODE = 0\text{V}$ , $I_{VOUT} = 0\text{mA}$		2 30 80 100 3.5	5 50 160 200 5.5	$\mu\text{A}$ $\mu\text{A}$ $\mu\text{A}$ $\mu\text{A}$ mA
$V_{RT}$	RT Regulation Voltage			1.200		V
$V_{OUT}$	$V_{OUT}$ Regulation Voltage	$MODE = 12\text{V}$ $MODE = 0\text{V}$		$-0.94 \cdot V_{IN}$ $-V_{IN}$		V V
$f_{OSC}$	Oscillator Frequency	$RT = \text{GND}$	450	500	550	kHz
$R_{OUT}$	Charge Pump Output Impedance	$MODE = 0\text{V}$ , $RT = \text{GND}$		32		$\Omega$
$I_{SHORT\_CKT}$	Max $I_{VOUT}$ Short-Circuit Current	$V_{OUT} = \text{GND}$	● 100	160	250	mA
$V_{MODE(H)}$	MODE Threshold Rising		●	1.1	2.0	V
$V_{MODE(L)}$	MODE Threshold Falling		● 0.4	1.0		V
$I_{MODE}$	MODE Pin Internal Pull-Down Current	$V_{IN} = MODE = 32\text{V}$		0.7		$\mu\text{A}$
<b>50mA Positive Regulator</b>						
	LDO <sup>+</sup> Output Voltage Range		● 1.2		32	V
$V_{ADJ^+}$	ADJ <sup>+</sup> Reference Voltage		● 1.176	1.200	1.224	V
$I_{ADJ^+}$	ADJ <sup>+</sup> Input Current	$V_{ADJ^+} = 1.2\text{V}$		-50	50	nA
$I_{LDO^+(SC)}$	LDO <sup>+</sup> Short-Circuit Current		● 50	100		mA
	Line Regulation			0.04		mV/V
	Load Regulation			0.03		mV/mA
$V_{DROPOUT^+}$	LDO <sup>+</sup> Dropout Voltage	$I_{LDO^+} = 50\text{mA}$		400	800	mV
	Output Voltage Noise	$C_{BYP^+} = 10\text{nF}$		100		$\mu\text{V}_{RMS}$
$V_{EN^+(H)}$	EN <sup>+</sup> Threshold Rising		●	1.1	2.0	V
$V_{EN^+(L)}$	EN <sup>+</sup> Threshold Falling		● 0.4	1.0		V
$I_{EN^+}$	EN <sup>+</sup> Pin Internal Pull-Down Current	$V_{IN} = EN^+ = 32\text{V}$		0.7		$\mu\text{A}$
<b>50mA Negative Regulator</b>						
	LDO <sup>-</sup> Output Voltage Range		● -32		-1.2	V
$V_{ADJ^-}$	ADJ <sup>-</sup> Reference Voltage		● -1.224	-1.200	-1.176	V
$I_{ADJ^-}$	ADJ <sup>-</sup> Input Current	$V_{ADJ^-} = -1.2\text{V}$		-50	50	nA
$I_{LDO^-(SC)}$	LDO <sup>-</sup> Short-Circuit Current		● 50	100		mA
	Line Regulation			0.002		mV/V
	Load Regulation			0.02		mV/mA
$V_{DROPOUT^-}$	LDO <sup>-</sup> Dropout Voltage	$I_{LDO^-} = 50\text{mA}$		200	500	mV
	Output Voltage Noise	$C_{BYP^-} = 10\text{nF}$		100		$\mu\text{V}_{RMS}$
$V_{EN(H)}$	EN <sup>-</sup> Threshold Rising		●	1.1	2.0	V
$V_{EN(L)}$	EN <sup>-</sup> Threshold Falling		● 0.4	1.0		V
$I_{EN^-}$	EN <sup>-</sup> Pin Internal Pull-Down Current	$V_{IN} = EN^- = 32\text{V}$		1.4		$\mu\text{A}$

## ELECTRICAL CHARACTERISTICS

**Note 1:** Stresses beyond those listed under Absolute Maximum Ratings may cause permanent damage to the device. Exposure to any Absolute Maximum Rating condition for extended periods may affect device reliability and lifetime.

**Note 2:** The LTC3260 is tested under pulsed load conditions such that  $T_J \approx T_A$ . The LTC3260E is guaranteed to meet specifications from 0°C to 85°C junction temperature. Specifications over the -40°C to 125°C operating junction temperature range are assured by design, characterization and correlation with statistical process controls. The LTC3260I is guaranteed over the -40°C to 125°C operating junction temperature range, the LTC3260H is guaranteed over the -40°C to 150°C operating junction temperature range and the LTC3260MP is tested and guaranteed over the full -55°C to 150°C operating junction temperature range. Note that the maximum ambient temperature consistent with

these specifications is determined by specific operating conditions in conjunction with board layout, the rated package thermal impedance and other environmental factors.

The junction temperature ( $T_J$ , in °C) is calculated from the ambient temperature ( $T_A$ , in °C) and power dissipation ( $P_D$ , in Watts) according to the formula:

$$T_J = T_A + (P_D \cdot \theta_{JA}),$$

where  $\theta_{JA} = 43^\circ\text{C/W}$  is the package thermal impedance.

**Note 3:** This IC includes overtemperature protection that is intended to protect the device during momentary overload conditions. Junction temperatures will exceed 150°C when overtemperature protection is active. Continuous operation above the specified maximum operating junction temperature may result in device degradation or failure.

## TYPICAL PERFORMANCE CHARACTERISTICS

( $T_A = 25^\circ\text{C}$ ,  $C_{FLY} = 1\mu\text{F}$ ,  $C_{IN} = C_{OUT} = C_{LDO+} = C_{LDO-} = 10\mu\text{F}$  unless otherwise noted)

**Oscillator Frequency vs Supply Voltage**

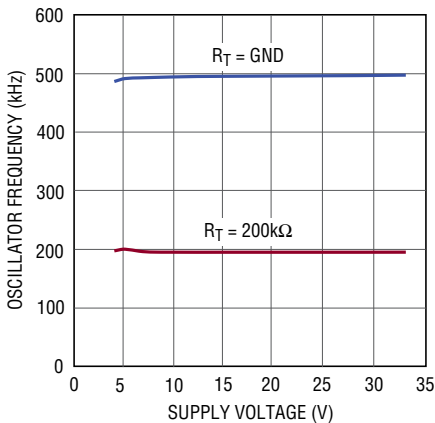

3260 G01

**Oscillator Frequency vs R<sub>T</sub>**

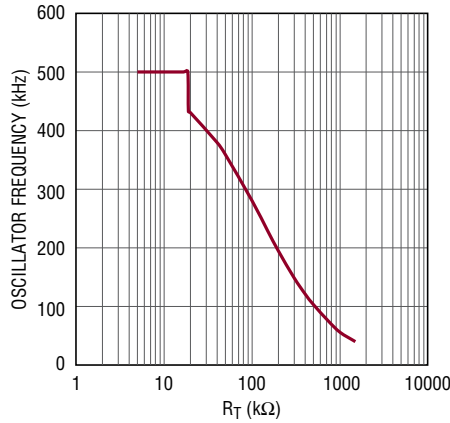

3260 G02

**Shutdown Current vs Temperature**

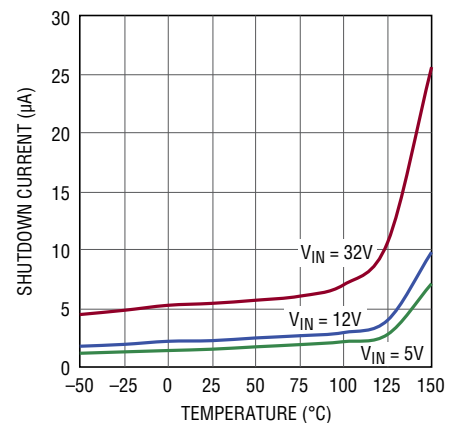

3260 G03

**Quiescent Current vs Temperature**

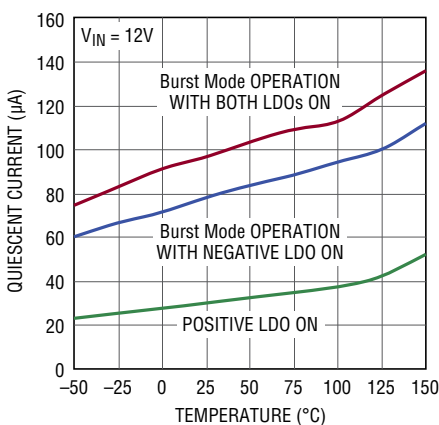

3260 G04

**Quiescent Current vs Supply Voltage (Constant Frequency Mode)**

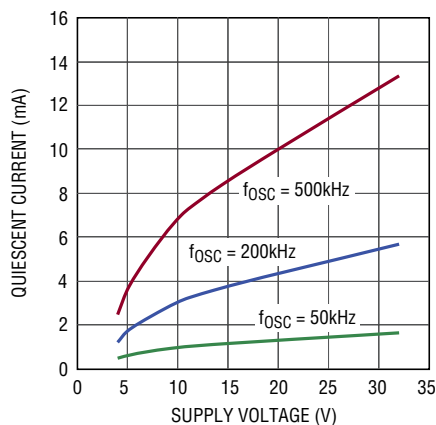

3260 G05

**Quiescent Current vs Temperature (Constant Frequency Mode)**

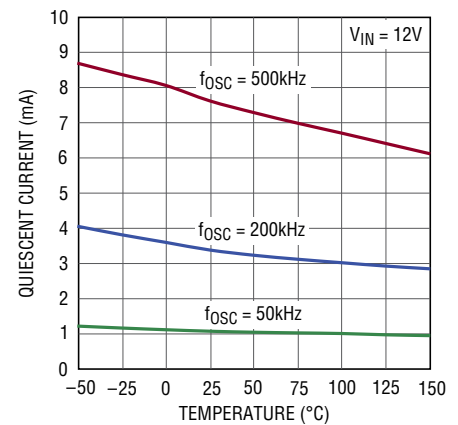

3260 G06

Rev. B

# TYPICAL PERFORMANCE CHARACTERISTICS

( $T_A = 25^\circ\text{C}$ ,  $C_{\text{FLY}} = 1\mu\text{F}$ ,  $C_{\text{IN}} = C_{\text{OUT}} = C_{\text{LDO}^+} = C_{\text{LDO}^-} = 10\mu\text{F}$  unless otherwise noted)

**Effective Open-Loop Resistance vs Temperature**

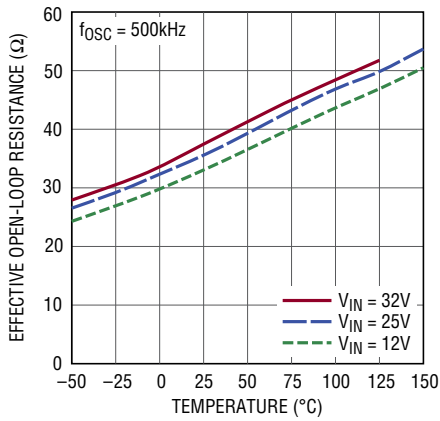

3260 G07

**V<sub>OUT</sub> Short-Circuit Current vs Supply Voltage**

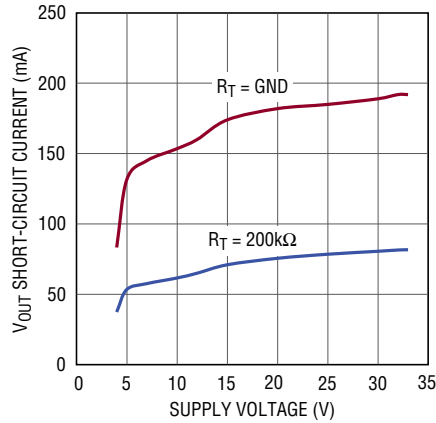

3260 G08

**Voltage Loss ( $V_{\text{IN}} - |V_{\text{OUT}}|$ ) vs Output Current (Constant Frequency Mode)**

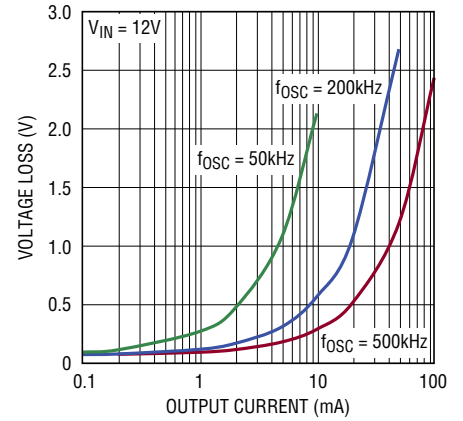

3260 G09

**Effective Open-Loop Resistance vs Supply Voltage**

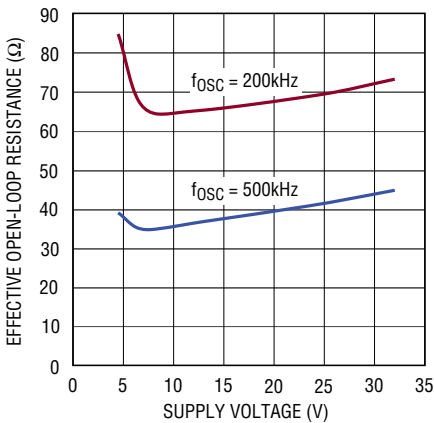

3260 G10

**ADJ<sup>+</sup> Pin Voltage vs Temperature**

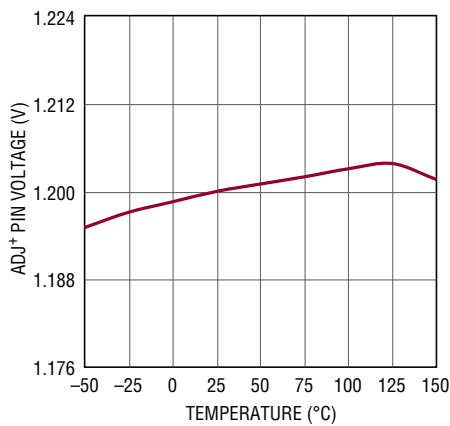

3260 G11

**LDO<sup>+</sup> Dropout Voltage vs Temperature**

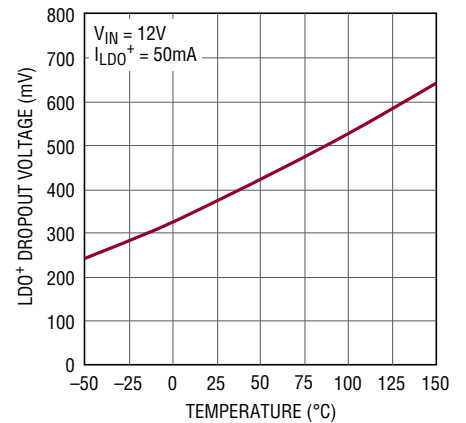

3260 G12

**LDO<sup>+</sup> Supply Rejection**

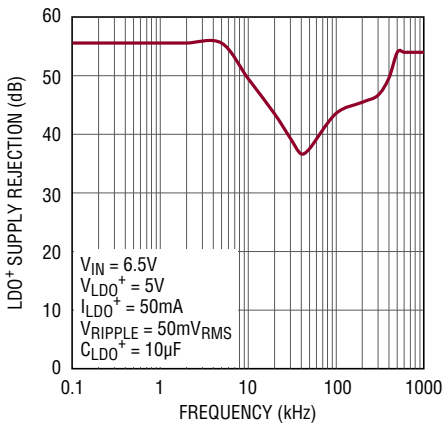

3260 G13

**LDO<sup>+</sup> GND Pin Current vs I<sub>LOAD</sub>**

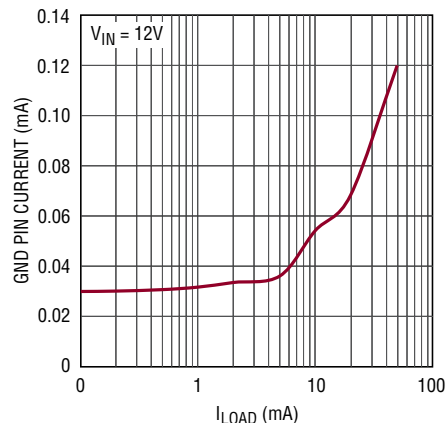

3260 G14

**LDO<sup>+</sup> Load Regulation**

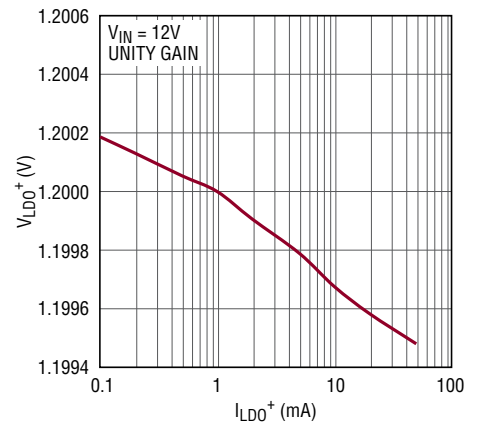

3260 G15

## TYPICAL PERFORMANCE CHARACTERISTICS

( $T_A = 25^\circ\text{C}$ ,  $C_{\text{FLY}} = 1\mu\text{F}$ ,  $C_{\text{IN}} = C_{\text{OUT}} = C_{\text{LDO}^+} = C_{\text{LDO}^-} = 10\mu\text{F}$  unless otherwise noted)

**ADJ<sup>-</sup> Pin Voltage vs Temperature**

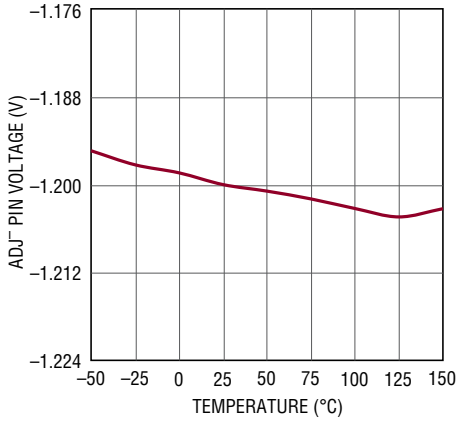

3260 G16

**LDO<sup>-</sup> Dropout Voltage vs Temperature**

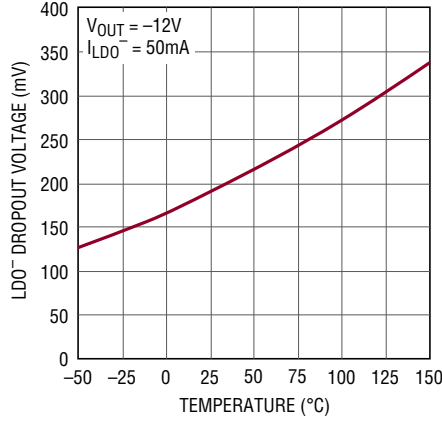

3260 G17

**LDO<sup>-</sup> Power Supply Rejection**

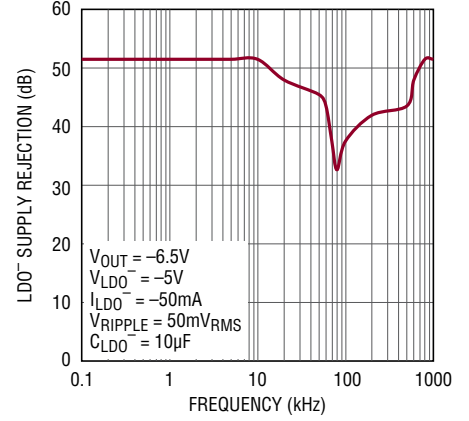

3260 G18

**LDO<sup>-</sup> Load Regulation**

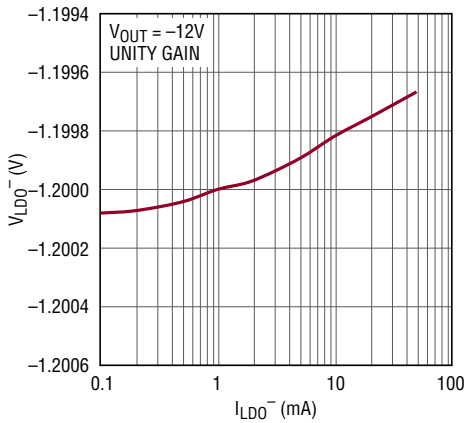

3260 G19

**LDO Rejection of V<sub>OUT</sub> Ripple**

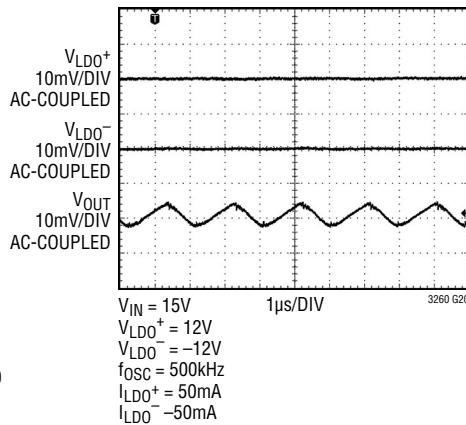

3260 G20

**LDO<sup>+</sup> Load Transient**

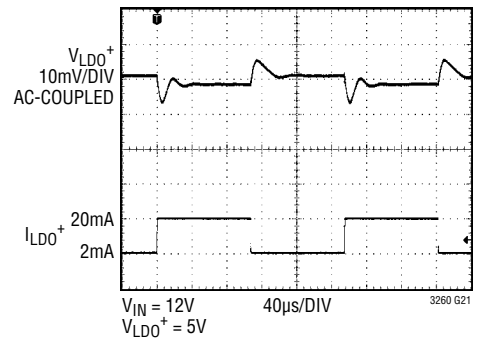

3260 G21

**LDO<sup>-</sup> Load Transient**

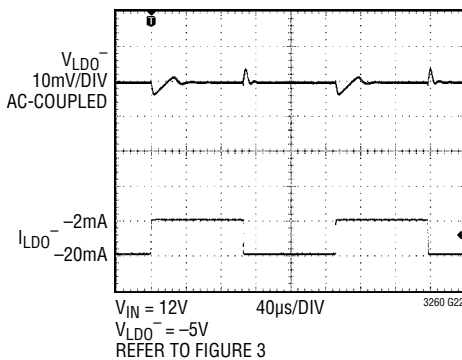

3260 G22

**V<sub>OUT</sub> Transient (Burst Mode Operation, MODE = H)**

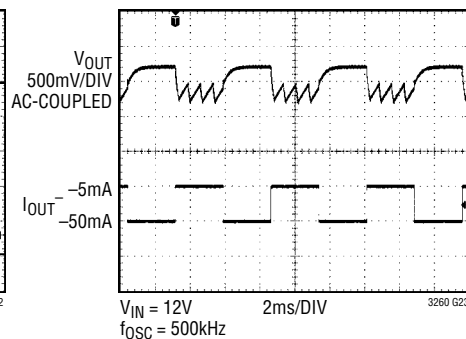

3260 G23

**V<sub>OUT</sub> Transient (MODE = Low to High)**

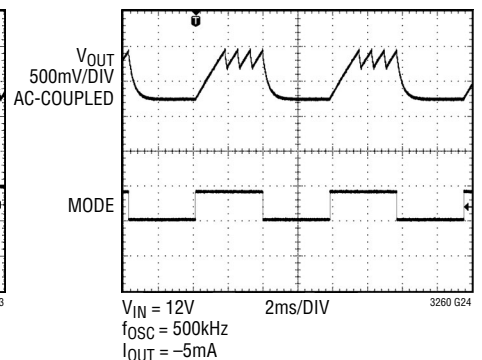

3260 G24

## PIN FUNCTIONS (DFN/MSOP)

**EN<sup>+</sup> (Pin 1/Pin 1):** Logic Input. A logic “high” on the EN<sup>+</sup> pin enables the positive low dropout (LDO<sup>+</sup>) regulator.

**RT (Pin 2/Pin 2):** Input Connection for Programming the Switching Frequency. The RT pin serves to a fixed 1.2V when the EN<sup>-</sup> pin is driven to a logic “high”. A resistor from RT to GND sets the charge pump switching frequency. If the RT pin is tied to GND, the switching frequency defaults to a fixed 500kHz.

**BYP<sup>-</sup> (Pin 3/Pin 3):** LDO<sup>-</sup> Reference Bypass Pin. Connect a capacitor from BYP<sup>-</sup> to GND to reduce LDO<sup>-</sup> output noise. Leave floating if unused.

**ADJ<sup>-</sup> (Pin 4/Pin 4):** Feedback Input for the Negative Low Dropout Regulator. This pin serves to a fixed voltage of -1.2V when the control loop is complete.

**LDO<sup>-</sup> (Pin 5/Pin 5):** Negative Low Dropout (LDO<sup>-</sup>) Linear Regulator Output. This pin requires a low ESR (equivalent series resistance) capacitor with at least 2μF capacitance to ground for stability.

**V<sub>OUT</sub> (Pin 6/Pin 6):** Charge Pump Output Voltage. In constant frequency mode (MODE = low) this pin is driven to -V<sub>IN</sub>. In Burst Mode operation, (MODE = high) this pin voltage is regulated to -0.94 • V<sub>IN</sub> using an internal burst comparator with hysteretic control.

**C<sup>-</sup> (Pin 7/Pin 7):** Flying Capacitor Negative Connection.

**C<sup>+</sup> (Pin 8/Pin 10):** Flying Capacitor Positive Connection.

**NC (Pins 8, 9 MSOP Only):** No Connect. These pins are not connected to the LTC3260 die. These pins should be left floating, connected to ground or shorted to adjacent pins.

**V<sub>IN</sub> (Pin 9/Pin 11):** Input Voltage for Both Charge Pump and Positive Low Dropout (LDO<sup>+</sup>) Regulator. V<sub>IN</sub> should be bypassed with a low impedance ceramic capacitor.

**LDO<sup>+</sup> (Pin 10/Pin 12):** Positive Low Dropout (LDO<sup>+</sup>) Output. This pin requires a low ESR capacitor with at least 2μF capacitance to ground for stability.

**EN<sup>-</sup> (Pin 11/Pin 13):** Logic Input. A logic “high” on the EN<sup>-</sup> pin enables the inverting charge pump as well as the negative LDO regulator.

**MODE (Pin 12/Pin 14):** Logic Input. The MODE pin determines the charge pump operating mode. A logic “high” on the MODE pin forces the charge pump to operate in Burst Mode operation regulating V<sub>OUT</sub> to approximately -0.94 • V<sub>IN</sub> with hysteretic control. A logic “low” on the MODE pin forces the charge pump to operate as an open-loop inverter with a constant switching frequency. The switching frequency in both modes is determined by an external resistor from the RT pin to GND. In Burst Mode operation, this represents the frequency of the burst cycles before the part enters the low quiescent current sleep state.

**ADJ<sup>+</sup> (Pin 13/Pin 15):** Feedback Input for the Positive Low Dropout (LDO<sup>+</sup>) Regulator. This pin serves to a fixed voltage of 1.2V when the control loop is complete.

**BYP<sup>+</sup> (Pin 14/Pin 16):** LDO<sup>+</sup> Reference Bypass Pin. Connect a capacitor from BYP<sup>+</sup> to GND to reduce LDO<sup>+</sup> output noise. Leave floating if unused.

**GND (Exposed Pad Pin 15/Exposed Pad Pin 17):** Ground. The exposed package pad is ground and must be soldered to the PC board ground plane for proper functionality and for rated thermal performance.

## BLOCK DIAGRAM

Note: Pin numbers are as per DFN package. Refer to the Pin Functions section for corresponding MSOP pin numbers.

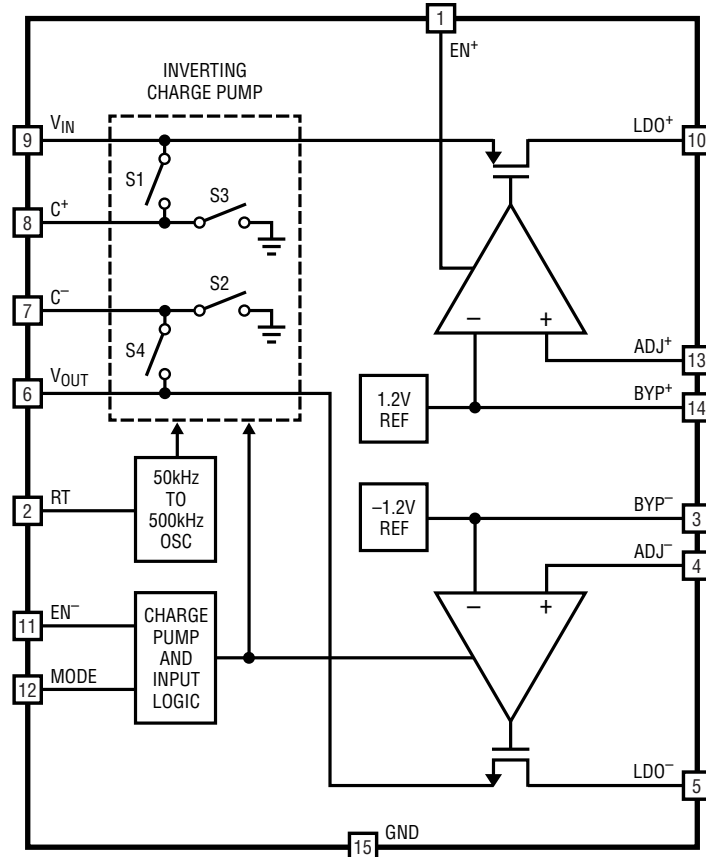

## OPERATION (Refer to the Operation)

The LTC3260 is a high voltage low noise dual output regulator. It includes an inverting charge pump and two LDO regulators to generate bipolar low noise supply rails from a single positive input. It supports a wide input power supply range from 4.5V to 32V.

### Shutdown Mode

In shutdown mode, all circuitry except the internal bias is turned off. The LTC3260 is in shutdown when a logic low is applied to both the enable inputs (EN+ and EN-). The LTC3260 only draws 2 $\mu$ A (typical) from the V<sub>IN</sub> supply in shutdown.

### Charge Pump Constant Frequency Operation

The LTC3260 provides low noise constant frequency operation when a logic low is applied to the MODE pin. The charge pump and oscillator circuit are enabled using the EN- pin. At the beginning of a clock cycle, switches S1 and S2 are closed. The external flying capacitor across the C+ and C- pins is charged to the V<sub>IN</sub> supply. In the second phase of the clock cycle, switches S1 and S2 are opened, while switches S3 and S4 are closed. In this configuration the C+ side of the flying capacitor is grounded and charge is delivered through the C- pin to V<sub>OUT</sub>. In steady state the V<sub>OUT</sub> pin regulates at -V<sub>IN</sub> less any voltage drop due to the load current on V<sub>OUT</sub> or LDO.

## OPERATION (Refer to the Block Diagram)

The charge transfer frequency can be adjusted between 50kHz and 500kHz using an external resistor on the RT pin. At slower frequencies the effective open-loop output resistance ( $R_{OL}$ ) of the charge pump is larger and it is able to provide smaller average output current. Figure 1 can be used to determine a suitable value of RT to achieve a required oscillator frequency. If the RT pin is grounded, the part operates at a constant frequency of 500kHz.

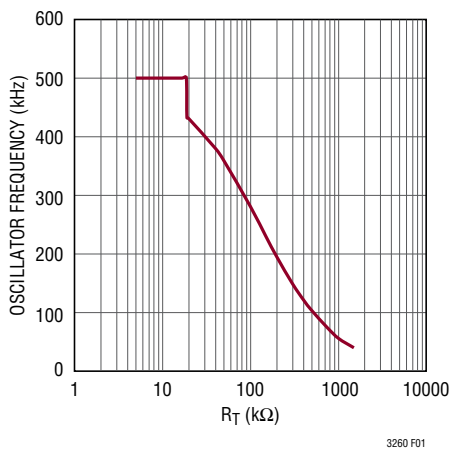

Figure 1. Oscillator Frequency vs  $R_T$

### Charge Pump Burst Mode Operation

The LTC3260 provides low power Burst Mode operation when a logic high is applied to the MODE pin. In Burst Mode operation, the charge pump charges the  $V_{OUT}$  pin to  $-0.94 \cdot V_{IN}$  (typical). The part then shuts down the internal oscillator to reduce switching losses and goes into a low current state. This state is referred to as the sleep state in which the IC consumes only about 100 $\mu$ A with both LDOs enabled. When the output voltage droops enough to overcome the burst comparator hysteresis, the part wakes up and commences charge pump cycles until output voltage exceeds  $-0.94 \cdot V_{IN}$  (typical). This mode provides lower operating current at the cost of higher output ripple and is ideal for light load operation.

The frequency of charging cycles is set by the external resistor on the RT pin. The charge pump has a lower  $R_{OL}$  at higher frequencies. For Burst Mode operation it is recommended that the RT pin be tied to GND. This

minimizes the charge pump  $R_{OL}$ , quickly charges the output up to the burst threshold and optimizes the duration of the low current sleep state.

### Charge Pump Soft-Start

The LTC3260 has built in soft-start circuitry to prevent excessive current flow during start-up. The soft-start is achieved by internal circuitry that slowly ramps the amount of current available at the output storage capacitor. The soft-start circuitry is reset in the event of a commanded shutdown or thermal shutdown.

### Charge Pump Short-Circuit/Thermal Protection

The LTC3260 has built-in short-circuit current limit as well as overtemperature protection. During a short-circuit condition, the part automatically limits its output current to approximately 160mA. If the junction temperature exceeds approximately 175°C the thermal shutdown circuitry disables current delivery to the output. Once the junction temperature drops back to approximately 165°C current delivery to the output is resumed. When thermal protection is active the junction temperature is beyond the specified operating range. Thermal protection is intended for momentary overload conditions outside normal operation. Continuous operation above the specified maximum operating junction temperature may impair device reliability.

### Positive Low Dropout Linear Regulator (LDO<sup>+</sup>)

The positive low dropout regulator (LDO<sup>+</sup>) supports a load of up to 50mA. The LDO<sup>+</sup> takes power from the  $V_{IN}$  pin and drives the LDO<sup>+</sup> output pin to a voltage programmed by the resistor divider connected between the LDO<sup>+</sup>, ADJ<sup>+</sup> and GND pins. For stability, the LDO<sup>+</sup> output must be bypassed to ground with a low ESR ceramic capacitor that maintains a capacitance of at least 2 $\mu$ F across operating temperature and voltage.

The LDO<sup>+</sup> is enabled or disabled via the EN<sup>+</sup> logic input pin. When the LDO<sup>+</sup> is enabled, a soft-start circuit ramps its regulation point from zero to the final value over a period of 75 $\mu$ s, reducing the inrush current on  $V_{IN}$ .

**OPERATION** (Refer to the Operation)

Figure 2 shows the LDO<sup>+</sup> regulator application circuit. The LDO<sup>+</sup> output voltage  $V_{LDO^+}$  can be programmed by choosing suitable values of R1 and R2 such that:

$$V_{LDO^+} = 1.2V \cdot \left( \frac{R1}{R2} + 1 \right)$$

An optional capacitor of 10nF can be connected from the BYP<sup>+</sup> pin to ground. This capacitor bypasses the internal 1.2V reference of the LTC3260 and improves the noise performance of the LDO<sup>+</sup>. If this function is not used the BYP<sup>+</sup> pin should be left floating.

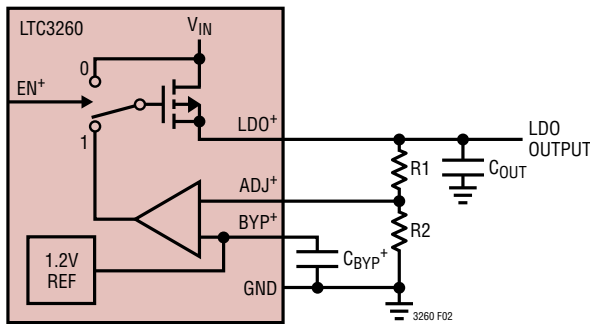

Figure 2. Positive LDO Application Circuit

**Negative Low Dropout Linear Regulator (LDO<sup>-</sup>)**

The negative low dropout regulator (LDO<sup>-</sup>) supports a load of up to 50mA. The LDO<sup>-</sup> takes power from the V<sub>OUT</sub> pin (output of the inverting charge pump) and drives the LDO<sup>-</sup> output pin to a voltage programmed by the resistor divider connected between the LDO<sup>-</sup>, ADJ<sup>-</sup> and GND pins. For stability, the LDO<sup>-</sup> output must be bypassed to ground with a low ESR ceramic capacitor that maintains a capacitance of at least 2μF across operating temperature and voltage.

The LDO<sup>-</sup> is enabled or disabled via the EN<sup>-</sup> logic input pin. Initially, when the EN<sup>-</sup> logic input is low, the charge pump circuitry is disabled and the V<sub>OUT</sub> pin is at GND. When EN<sup>-</sup> is switched high, the V<sub>OUT</sub> pin will be driven

negative by the charge pump circuitry. Soft-start circuitry in the charge pump also provides soft-start functionality for the LDO<sup>-</sup> and prevents excessive inrush currents.

Figure 3 shows the LDO<sup>-</sup> regulator application circuit. The LDO<sup>-</sup> output voltage  $V_{LDO^-}$  can be programmed by choosing suitable values of R1 and R2 such that:

$$V_{LDO^-} = -1.2V \cdot \left( \frac{R1}{R2} + 1 \right)$$

When the inverting charge pump is in Burst Mode operation (MODE = high), the typical hysteresis on the V<sub>OUT</sub> pin is 2% of V<sub>IN</sub> voltage. The LDO<sup>-</sup> voltage should be set high enough above V<sub>OUT</sub> in order to prevent LDO<sup>-</sup> from entering dropout during normal operation.

An optional capacitor of 10nF can be connected from the BYP<sup>-</sup> pin to ground. This capacitor bypasses the internal -1.2V reference of the LTC3260 and improves the noise performance of the LDO<sup>-</sup>. If this function is not used the BYP<sup>-</sup> pin should be left floating.

In order to improve transient response, an optional capacitor, C<sub>ADJ<sup>-</sup></sub>, may be used as shown in Figure 3. A recommended value for C<sub>ADJ<sup>-</sup></sub> is 10pF. Experimentation with capacitor values between 2pF and 22pF may yield improved transient response.

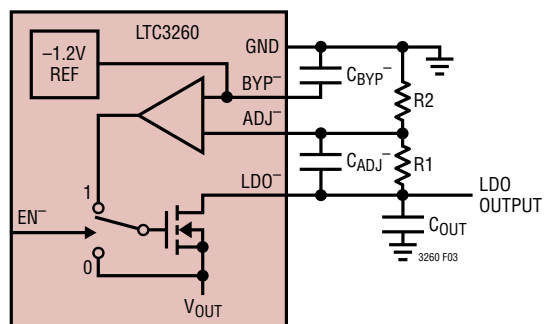

Figure 3. Negative LDO Application Circuit

## APPLICATIONS INFORMATION

### Effective Open-Loop Output Resistance

The effective open-loop output resistance ( $R_{OL}$ ) of a charge pump is a very important parameter which determines the strength of the charge pump. The value of this parameter depends on many factors such as the oscillator frequency ( $f_{OSC}$ ), value of the flying capacitor ( $C_{FLY}$ ), the nonoverlap time, the internal switch resistances ( $R_S$ ) and the ESR of the external capacitors.

Typical  $R_{OL}$  values as a function of temperature are shown in Figure 4.

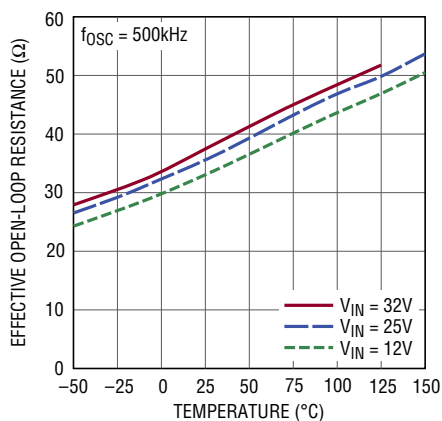

Figure 4. Typical  $R_{OL}$  vs Temperature

### Input/Output Capacitor Selection

The style and value of capacitors used with the LTC3260 determine several important parameters such as regulator control loop stability, output ripple, charge pump strength and minimum turn-on time. To reduce noise and ripple, it is recommended that low ESR ceramic capacitors be used for the charge pump and LDO outputs. All capacitors should retain at least 2 $\mu$ F of capacitance over operating temperature and bias voltage. Tantalum and aluminum capacitors can be used in parallel with a ceramic capacitor to increase the total capacitance but should not be used alone because of their high ESR. In constant frequency mode, the value of  $C_{OUT}$  directly controls the amount of output ripple for a given load current. Increasing the size of  $C_{OUT}$  will reduce the output ripple at the expense of

higher minimum turn-on time. The peak-to-peak output ripple at the  $V_{OUT}$  pin is approximately given by the expression:

$$V_{RIPPLE(P-P)} \approx \frac{I_{OUT}}{C_{OUT}} \left[ \frac{1}{f_{OSC}} - t_{ON} \right]$$

where  $C_{OUT}$  is the value of the output capacitor,  $f_{OSC}$  is the oscillator frequency and  $t_{ON}$  is the on-time of the oscillator (1 $\mu$ s typical).

Just as the value of  $C_{OUT}$  controls the amount of output ripple, the value of  $C_{IN}$  controls the amount of ripple present at the input ( $V_{IN}$ ) pin. The amount of bypass capacitance required at the input depends on the source impedance driving  $V_{IN}$ . For best results it is recommended that  $V_{IN}$  be bypassed with at least 2 $\mu$ F of low ESR capacitance. A high ESR capacitor such as tantalum or aluminum will have higher input noise than a low ESR ceramic capacitor. Therefore, a ceramic capacitor is recommended as the main bypass capacitance with a tantalum or aluminum capacitor used in parallel if desired.

### Flying Capacitor Selection

The flying capacitor controls the strength of the charge pump. A 1 $\mu$ F or greater ceramic capacitor is suggested for the flying capacitor for applications requiring the full rated output current of the charge pump.

For very light load applications, the flying capacitor may be reduced to save space or cost. For example, a 0.2 $\mu$ F capacitor might be sufficient for load currents up to 20mA. A smaller flying capacitor leads to a larger effective open-loop resistance ( $R_{OL}$ ) and thus limits the maximum load current that can be delivered by the charge pump.

### Ceramic Capacitors

Ceramic capacitors of different materials lose their capacitance with higher temperature and voltage at different rates. For example, a capacitor made of X5R or X7R material will retain most of its capacitance from -40°C to 85°C whereas a Z5U or Y5V style capacitor will lose

## APPLICATIONS INFORMATION

considerable capacitance over that range. Z5U and Y5V capacitors may also have a poor voltage coefficient causing them to lose 60% or more of their capacitance when the rated voltage is applied. Therefore when comparing different capacitors, it is often more appropriate to compare the amount of achievable capacitance for a given case size rather than discussing the specified capacitance value. The capacitor manufacturer's data sheet should be consulted to ensure the desired capacitance at all temperatures and voltages. Table 1 is a list of ceramic capacitor manufacturers and their websites.

**Table 1.**

AVX	<a href="http://www.avxcorp.com">www.avxcorp.com</a>
Kemet	<a href="http://www.kemet.com">www.kemet.com</a>
Murata	<a href="http://www.murata.com">www.murata.com</a>
Taiyo Yuden	<a href="http://www.t-yuden.com">www.t-yuden.com</a>
Vishay	<a href="http://www.vishay.com">www.vishay.com</a>
TDK	<a href="http://www.component.tdk.com">www.component.tdk.com</a>

### Layout Considerations

Due to high switching frequency and high transient currents produced by LTC3260, careful board layout is necessary for optimum performance. A true ground plane and short connections to all the external capacitors will improve performance and ensure proper regulation under all conditions. Figure 5 shows an example layout for the LTC3260.

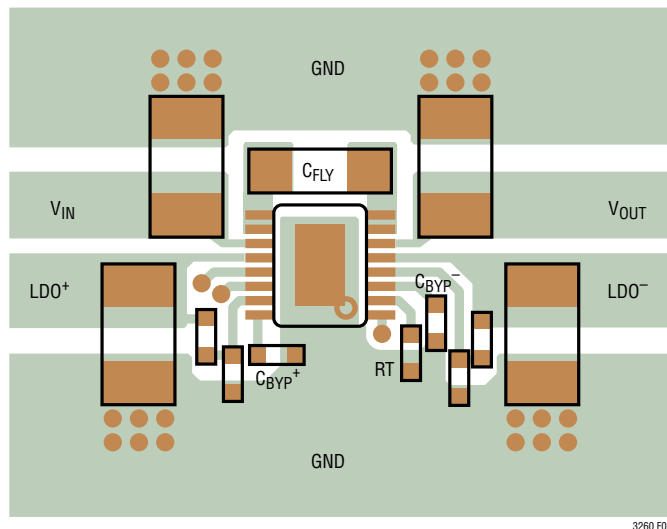

**Figure 5. Recommended Layout**

The flying capacitor nodes  $C^+$  and  $C^-$  switch large currents at a high frequency. These nodes should not be routed close to sensitive pins such as the LDO feedback pins ( $ADJ^+$  and  $ADJ^-$ ) and internal reference bypass pins ( $BYP^+$  and  $BYP^-$ ).

### Thermal Management

At high input voltages and maximum output current, there can be substantial power dissipation in the LTC3260. If the junction temperature increases above approximately  $175^\circ\text{C}$ , the thermal shutdown circuitry will automatically deactivate the output. To reduce the maximum junction temperature, a good thermal connection to the PC board ground plane is recommended. Connecting the exposed pad of the package to a ground plane under the device on two layers of the PC board can reduce the thermal resistance of the package and PC board considerably.

### Derating Power at High Temperatures

To prevent an overtemperature condition in high power applications, Figure 6 should be used to determine the maximum combination of ambient temperature and power dissipation.

The power dissipated in the LTC3260 should always fall under the line shown for a given ambient temperature. The power dissipated in the LTC3260 has three components.

Power dissipated in the positive LDO:

$$P_{LDO^+} = (V_{IN} - V_{LDO^+}) \cdot I_{LDO^+}$$

Power dissipated in the negative LDO:

$$P_{LDO^-} = (|V_{OUT}| - |V_{LDO^-}|) \cdot I_{LDO^-} \text{ and}$$

Power dissipated in the inverting charge pump:

$$P_{CP} = (V_{IN} - |V_{OUT}|) \cdot (I_{OUT} + I_{LDO^-})$$

where  $I_{OUT}$  denotes any additional current that might be pulled directly from the  $V_{OUT}$  pin. The  $LDO^-$  current is also supplied by the charge pump through  $V_{OUT}$  and is therefore included in the charge pump power dissipation.

The total power dissipation of the LTC3260 is given by:

$$P_D = P_{LDO^+} + P_{LDO^-} + P_{CP}$$

## APPLICATIONS INFORMATION

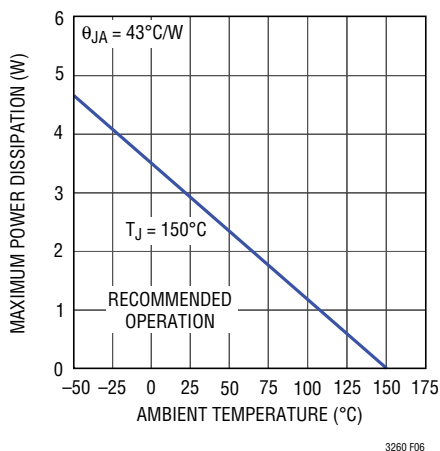

Figure 6. Maximum Power Dissipation vs Ambient Temperature

The derating curve in Figure 6 assumes a maximum thermal resistance,  $\theta_{JA}$ , of 43°C/W for the package. This can be achieved with a four layer PCB that includes 2oz Cu traces and six vias from the exposed pad of the LTC3260 to the ground plane.

It is recommended that the LTC3260 be operated in the region corresponding to  $T_J \leq 150^\circ\text{C}$  for continuous operation as shown in Figure 6. Operation beyond 150°C should be avoided as it may degrade part performance and lifetime. At high temperatures, typically around 175°C, the part is placed in thermal shutdown and all outputs are disabled. When the part cools back down to a low enough temperature, typically around 165°C, the outputs are re-enabled and the part resumes normal operation.

## TYPICAL APPLICATIONS

### Low Power ±24V Power Supply from a Single-Ended 28V Input Supply

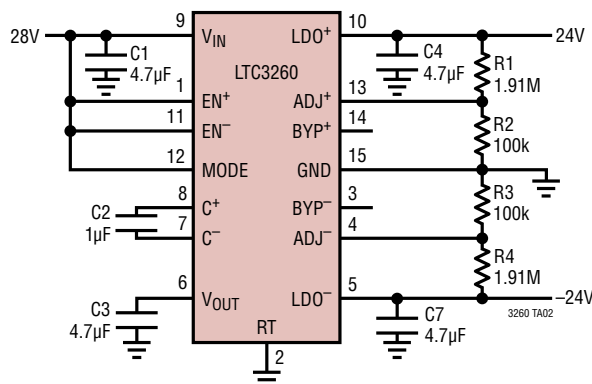

### High Voltage Input to Bipolar Output with Highly Efficient Dividing/Inverting Charge Pump

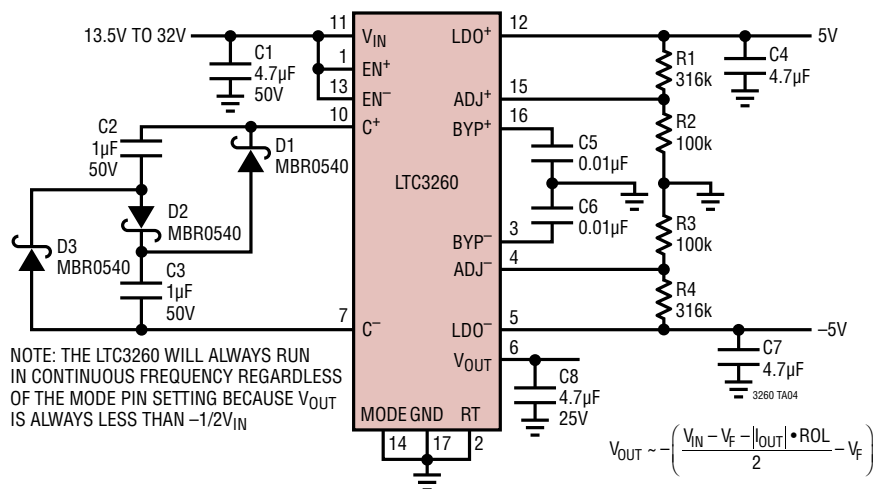

## TYPICAL APPLICATIONS

28V Dual Tracking Bipolar Supply with Outputs from  $\pm 5V$  to  $\pm 25V$

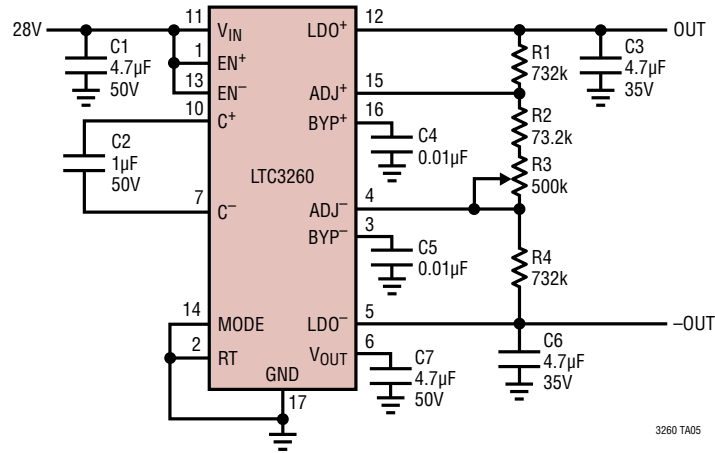



**PACKAGE DESCRIPTION**

**MSE Package**  
**16-Lead Plastic MSOP, Exposed Die Pad**  
 (Reference LTC DWG # 05-08-1667 Rev F)

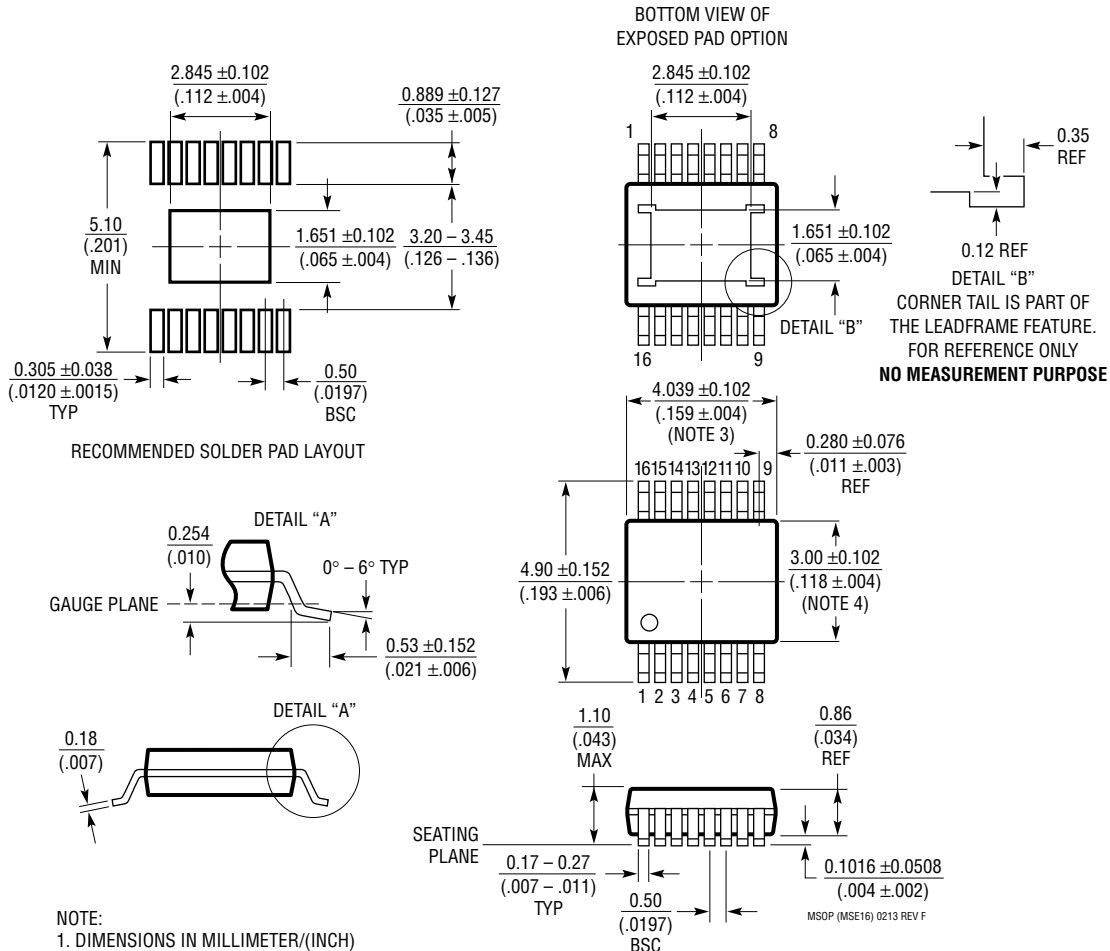

- NOTE:**
1. DIMENSIONS IN MILLIMETER/(INCH)
  2. DRAWING NOT TO SCALE
  3. DIMENSION DOES NOT INCLUDE MOLD FLASH, PROTRUSIONS OR GATE BURRS.  
 MOLD FLASH, PROTRUSIONS OR GATE BURRS SHALL NOT EXCEED 0.152mm (.006") PER SIDE
  4. DIMENSION DOES NOT INCLUDE INTERLEAD FLASH OR PROTRUSIONS.  
 INTERLEAD FLASH OR PROTRUSIONS SHALL NOT EXCEED 0.152mm (.006") PER SIDE
  5. LEAD COPLANARITY (BOTTOM OF LEADS AFTER FORMING) SHALL BE 0.102mm (.004") MAX
  6. EXPOSED PAD DIMENSION DOES INCLUDE MOLD FLASH. MOLD FLASH ON E-PAD SHALL NOT EXCEED 0.254mm (.010") PER SIDE.

## REVISION HISTORY

REV	DATE	DESCRIPTION	PAGE NUMBER
A	09/12	Changed Operating Junction Temperature.	2
		Add H- and MP-grade options.	Throughout
		Add Junction to heading of Electrical Characteristics table.	3
		Add H- and MP-grade into Note 2.	4
		Modified Shutdown Current vs Temperature curve for operation to 150°C.	4
		Modified Quiescent Current vs Temperature curve for operation to 150°C.	4
		Corrected Figure 5 Pinout $R_T$ and $C_{BYP}$ .	12
		Removed Thermal Shutdown curve from Figure 6.	13
		Clarified 150°C Operation in Derating Power section.	12, 13
		Updated Related Parts list.	18
B	11/21	Added AEC-Q100 Qualification in Progress statement.	1
		Added #W models in Ordering Information table.	2

## TYPICAL APPLICATION

Low Noise  $\pm 12V$  Power Supply from a Single-Ended 15V Input Supply (Frequency = 200kHz)

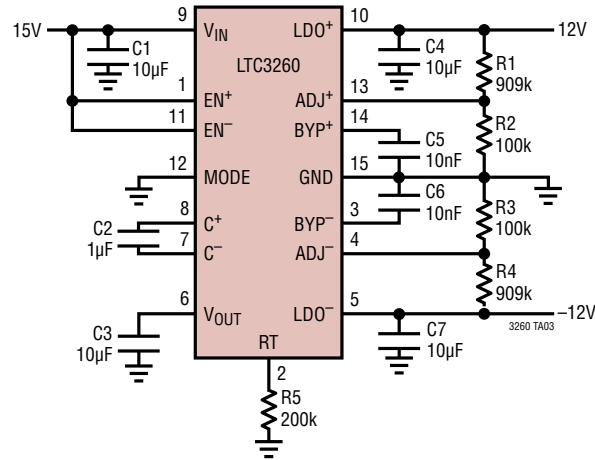

## RELATED PARTS

PART NUMBER	DESCRIPTION	COMMENTS
<a href="#">LTC1144</a>	Switched-Capacitor Wide Input Range Voltage Converter with Shutdown	Wide Input Voltage Range: 2V to 18V, $I_{SD} < 8\mu A$ , SO8 Package
<a href="#">LTC1514/LTC1515</a>	Step-Up/Step-Down Switched-Capacitor DC/DC Converters	$V_{IN}$ : 2V to 10V, $V_{OUT}$ : 3.3V to 5V, $I_Q = 60\mu A$ , SO8 Package
<a href="#">LT®1611</a>	150mA Output, 1.4MHz Micropower Inverting Switching Regulator	$V_{IN}$ : 0.9V to 10V, $V_{OUT} = \pm 34V$ , ThinSOT™ Package
<a href="#">LT1614</a>	250mA Output, 600kHz Micropower Inverting Switching Regulator	$V_{IN}$ : 0.9V to 6V, $V_{OUT} = \pm 30V$ , $I_Q = 1mA$ , MS8, SO8 Packages
<a href="#">LTC1911</a>	250mA, 1.5MHz Inductorless Step-Down DC/DC Converter	$V_{IN}$ : 2.7V to 5.5V, $V_{OUT} = 1.5V/1.8V$ , $I_Q = 180\mu A$ , MS8 Package
<a href="#">LTC3250/LTC3250-1.2/LTC3250-1.5</a>	Inductorless Step-Down DC/DC Converters	$V_{IN}$ : 3.1V to 5.5V, $V_{OUT} = 1.2V, 1.5V$ , $I_Q = 35\mu A$ , ThinSOT Package
<a href="#">LTC3251</a>	500mA Spread Spectrum Inductorless Step-Down DC/DC Converter	$V_{IN}$ : 2.7V to 5.5V, $V_{OUT}$ : 0.9V to 1.6V, 1.2V, 1.5V, $I_Q = 9\mu A$ , MS10E Package
<a href="#">LTC3252</a>	Dual 250mA, Spread Spectrum Inductorless Step-Down DC/DC Converter	$V_{IN}$ : 2.7V to 5.5V, $V_{OUT}$ : 0.9V to 1.6V, $I_Q = 50\mu A$ , DFN12 Package
<a href="#">LT1054/LT1054L</a>	Switched-Capacitor Voltage Converters with Regulator	$V_{IN}$ : 3.5V to 15V/7V, $I_{OUT} = 100mA/125mA$ , N8, SO8, SO16 Packages
<a href="#">LTC3261</a>	High Voltage, Low Quiescent Current Inverting Charge Pump	$V_{IN}$ : 4.5V to 32V, $V_{OUT} = -V_{IN}$ , $I_{OUT} = 100mA$ , MSOP-12 Package